



Flight Light Inc.
2708 47th Ave.
Sacramento, California, U.S.A.
95822-3806

PH (916) 394-2800 FX (916) 394-2809
TF (800) 806-3548 EM info@flightlight.com

Radio-Controlled Solar-Powered Airfield Lighting Avlite

Typical Applications

- Defense Deployments
- Commercial and Regional Airports
- Humanitarian Programs
- Emergency and Temporary Airfield Lighting

Major Benefits

- Remotely switch between infrared and visible light
- SHUT DOWN or turn all lights 'ON' remotely within seconds
- Allocate lights into 'light groups', and remotely control each group
- Change light colors remotely
- Set units to synchronized flashing
- An intelligent system, with practically unlimited range
- Each light incorporates leading technology

The Avlite Systems radio-controlled airport lighting system is a solar-powered LED lighting package designed to offer airports, defense, and aid agencies complete flexibility and enormous advantages over traditional fixtures.

The system is operated by a wireless handheld controller, which enables personnel to remotely activate and set specific characteristics of lights within their airfield.

Lights can be allocated to up to 15 'groups', such as taxiways, runway edge or threshold, and each group can be controlled independently.

The operator can change the color of each light in the group remotely by selecting between internal LED light banks - greatly expanding the flexibility of the system.

For defense applications, models can be supplied with the ability to remotely switch between visual and infrared light output.



In addition to switching between operating colors, lights can be set to any of over 250 flash patterns, including MORSE CODE. Lights set to the same flash rate will automatically synchronize with each other to provide clear perimeter or security marking.

Using advanced proprietary software, the airfield lighting system has a practically unlimited operational range. The operating range of the hand-held controller is up to 1.5km - after which the furthest light in range will relay the message to lights falling outside this area.

Avlite Systems is a world leader in the production of solar-powered LED airfield lighting systems, deployed throughout some of the most demanding regions by customers including the

US Army and US Air Force.

Each light is solar-powered, and will automatically charge the integrated battery during daylight hours. The internal battery has a life expectancy of 5 years, after which can be readily changed on-site by the operator.

The models use LEDs as a light-source, which means there are no globes to change - ever.

The coupling of advanced embedded-systems electronics, and LED and solar technology, allows for an airfield lighting package which can be deployed in minutes and can operate maintenance-free for many years - all this without the need for external power or underground trenching and cabling.

Visit our web site: www.flightlight.com



Flight Light Inc.
 2708 47th Ave.
 Sacramento, California, U.S.A.
 95822-3806

PH (916) 394-2800 FX (916) 394-2809
TF (800) 806-3548 EM info@flightlight.com

Radio-Controlled Solar-Powered Airfield Lighting Avlite

System Components:

Wireless Handheld Controller

The handheld wireless controller enables personnel to remotely activate and set specific characteristics of lights within their airfield, via 128-bit encrypted RF data.

Lights may be designated into up to 15 independent groups, and then interrogated to specify individual light profiles such as light flash characteristic, intensity and color (LED banks). In addition the lights may be manually activated via the controller, or set to automatically begin operation via the internal light sensor. The straight-forward menu makes the radio-controlled airfield lighting system very easy to operate.

The lightweight unit has an operational range of up to 1.5km, and features a heavy-duty aluminum housing, LCD/OLED screen, RF aerial and 4 press buttons for parameter control. An IP67 rated charging plug enables ease of battery recharge.



PC Interface (optional)

In addition to all the features available via the wireless handheld controller, users may access and interrogate their airfield lights via PC interface. All system features available from the handheld wireless controller are available from the interface, for ease of use and accessibility.

Avlite Systems PC interface Command Center allows the user the ability to control the entire airfield without leaving their desk. Lights can be controlled as easily as selecting one of the many settings and pressing the Send ICD Message button.

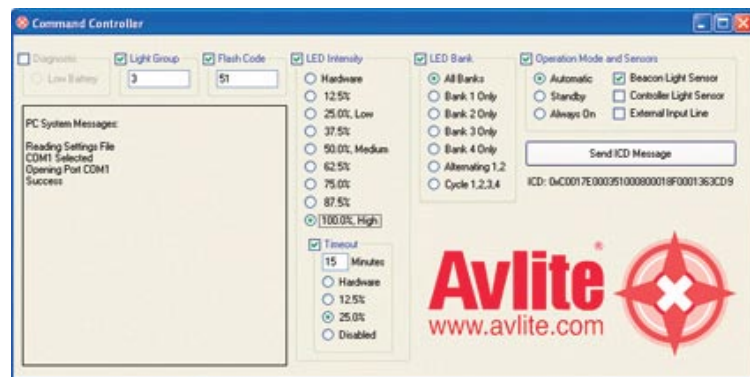

Visit our web site: www.flightlight.com



Flight Light Inc.
2708 47th Ave.
Sacramento, California, U.S.A.
95822-3806

PH (916) 394-2800 FX (916) 394-2809
TF (800) 806-3548 EM info@flightlight.com

Radio-Controlled Solar-Powered Airfield Lighting Avlite

Radio-Controlled AV70

The AV70 solar-powered LED airfield light has an internal RF module and antenna to receive encrypted command messages from the handheld controller. The light is completely self-contained, and is compliant with ICAO standards (ICAO Annex 14 Volume 1, "Aerodrome Design and Operations", Fourth edition July 2004, paragraph 5.3.17.7.).

The solar modules will continue to charge the unit during daylight hours, and at night the light will begin normal operation.

The model will operate maintenance-free for many years, and has been tried and tested in some of the world's most demanding regions including Iraq, Afghanistan, and the Australian Outback.

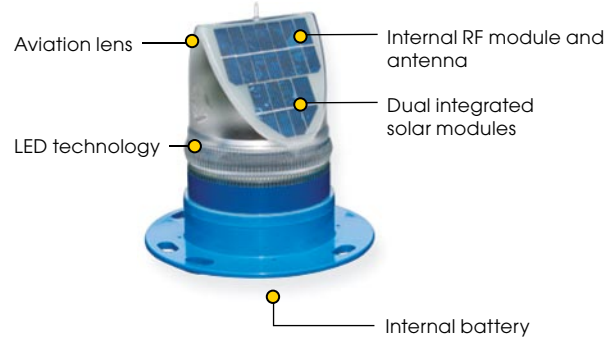

Radio-Controlled AVC420

The AVC420 radio-controlled solar aviation light is designed to meet the ICAO requirements for runway edge fixtures. The light is available in a variety of colors to suit runway edge and threshold applications, and includes an internal RF module and antenna to receive encrypted command messages from the wireless controller.

The AVC420 also has an IR option, and can be switched between IR and visual light for covert operations.

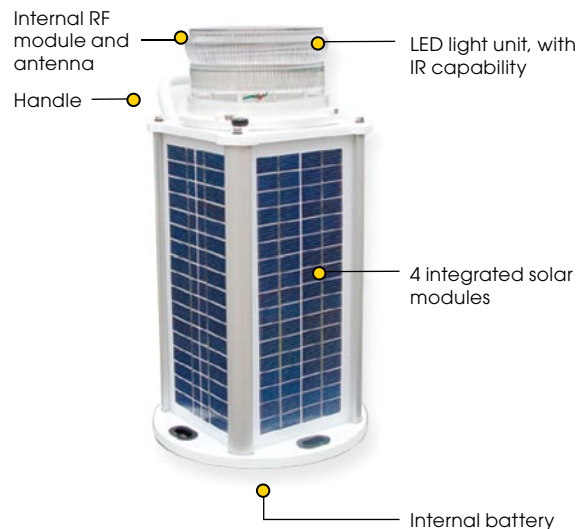

Visit our web site: www.flightlight.com



Flight Light Inc.
 2708 47th Ave.
 Sacramento, California, U.S.A.
 95822-3806

PH (916) 394-2800 FX (916) 394-2809
TF (800) 806-3548 EM info@flightlight.com

Radio-Controlled Solar-Powered Airfield Lighting Avlite

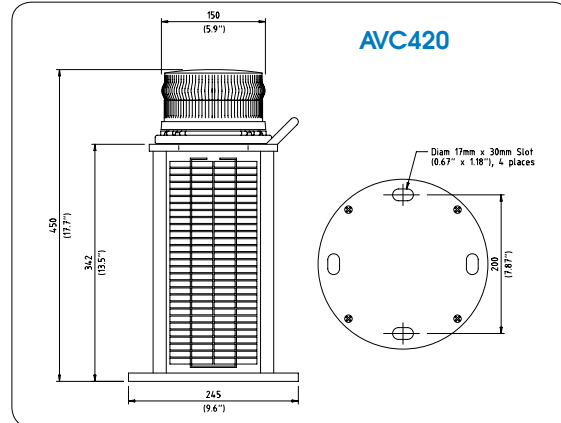
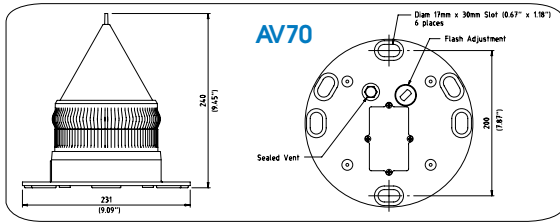

SPECIFICATIONS •

Light Characteristics

Light Source
 Available Colours
 High Intensity (temporary)
 Medium Intensity (temporary)
 Standard Intensity
 Horizontal Output (degrees)
 Vertical Divergence (degrees)
 Reflector Type

Available Flash Characteristics

Intensity Adjustments
 LED Life Expectancy (hours)

Electrical Characteristics

Operating Voltage (v)
 Autonomy
 Temperature Range
 Radio

Solar Characteristics

Solar Module Type
 Output (watts)
 Solar Module Efficiency (%)
 Charging Regulation

Power Supply

Battery Type Battery
 Capacity (Ah)
 Nominal Voltage (v)

Physical Characteristics

Body Material
 Lens Material
 Lens Diameter (mm/inches)
 Lens Design
 Mounting
 Height (mm/inches)
 Width (mm/inches)
 Mass (kg/lbs)
 Product Life Expectancy

Certifications

CE
 Quality Assurance
 Waterproof/Dustproof

Intellectual Property

Patents
 Trademarks

Warranty

Options Available

AV70

12 ultra-high intensity LEDs
 Red, Green, White, Yellow, Amber, Blue,
 Sectored Combinations
 25cd (white)
 12cd
 7cd
 360
 0 to +10
 Omnidirectional 360° LED Reflector
 (US Pat. No. 6,667,582. AU Pat. No. 778,918)
 Fixed-on as standard
 (>250 available (user-adjustable))
 Via radio modem or manually
 >100,000

Multicrystalline
 2.5
 14
 Microprocessor controlled

High grade NiMh – Environment friendly
 16
 3.6

LEXAN® Polycarbonate – UV stabilized
 LEXAN® Polycarbonate – UV stabilized
 140 / 5 1/2
 External optics with interior flute design
 6 x 17mm holes on 200mm PCD
 240 / 9 1/2
 231 / 9 1/8
 1.1 / 2 3/8
 Up to 12 years

EN61000-6-3:1997. EN61000-6-1:1997
 ISO9001:2000
 IP68

US Pat. No. 6,667,582. AU Pat. No. 778,918
 AVLITE® is a registered trademark of
 Avlite Systems
 Full 3 year warranty

• IR

AVC420

36 ultra-high intensity LEDs
 Red, Green, White, Yellow, Amber, Blue,
 Sectored Combinations
 125cd (white)
 50cd
 >25cd
 360
 0 to +15
 Omnidirectional 360° LED Reflector
 (US Pat. No. 6,667,582. AU Pat. No. 778,918)
 Fixed-on as standard
 (>250 available (user-adjustable))
 Via radio modem or manually
 >100,000

Multicrystalline
 16
 14
 Regulator controlled

SLA (Sealed Lead Acid)
 20
 12

7-stage powder-coated aluminum
 LEXAN® Polycarbonate – UV stabilized
 150 / 5 7/8
 External optics with interior flute design
 4 x 17mm holes on 200mm PCD
 450 / 17 3/4
 245 / 9 2/3
 10.8 / 23 3/4
 Up to 12 years

EN61000-6-3:1997. EN61000-6-1:1997
 ISO9001:2000
 IP68

US Pat. No. 6,667,582. AU Pat. No. 778,918
 AVLITE® is a registered trademark of
 Avlite Systems
 Full 3 year warranty

• IR

• Specifications subject to change or variation without notice

Visit our web site: www.flightlight.com