



Flight Light Inc.
2708 47th Ave.
Sacramento, California, U.S.A.
95822-3806

atg airports (formerly ALSTOM)
ZA181 High Intensity
Runway Centerline and
Touch Down Zone Inset Light
FAA Compliant: L-850A & B

PH (916) 394-2800 FX (916) 394-2809
TF (800) 806-3548 EM info@flightlight.com

Compliance and Applications

FAA Compliant: L-850A, L-850B
AC 150/5345-46D
NATO Stanag 3316
ICAO Annex 14

Category I, II and III all weather operation airfield lighting systems.

Suitable for use as high intensity inset runway centerline and touch down zone lights.

Features

- Lightweight and robust aluminum alloy construction.
- Prism removal and replacement achieved without need for adhesives or sealants.
- Pre-focused optics simplify maintenance.
- Pressure test plug ensures moisture-proof light cavity.
- Installation and maintenance manual AVD 104.

Specifications

- Low profile: 0.47" (12mm) projection.
- Long life lamps: 1,500 hours at full intensity. Over 3,500 hours in normal use.
- 6.6A from 45W, 100W, or 200W isolating transformer. TDZ uses 1@45/49W lamp. RWCL uses 2@45/49W lamps.
- Corrosion resistant anodized finish. Stainless steel fasteners.
- Net weight 11 lb. (5kg). Gross weight 13.2 lb. (6kg). Carton size 8.7 in. x 8.7 in. x 5 in. (220mm x 220mm x 126mm).



Application Variations

FAA#	Application	Config.	Lamps	Color	Code
L-850A ..	Centerline.....	Bidirectional.....	2.....	White/White.....	80-ZA181iWW
L-850A ..	Centerline.....	Bidirectional.....	2.....	White/Red.....	80-ZA181iWR
L-850A ..	Centerline.....	Unidirectional.....	1.....	Red/Blank.....	80-ZA181iRX
L-850B...	Touch down zone ...	Unidirectional.....	1.....	White/Blank.....	80-ZA181iWX

Ordering Code

Fixture	Color (LH)	Color (RH)	Plug Leads	Lamps	Bypass
80-ZA181i	W: White R: Red X: Blank	W: White R: Red X: Blank	1: Single 'B' type 2: Two 'B' type	1: Single 45/49W 2: Two 45/49W 3: Single 105W 4: Two 105W	B: Lamp bypass Blank: No bypass

If mounting on L-868B base, order with 12" FAA L-868B mounting adapter (30-AA122820), sold separately.

80-ZA181i					
-----------	--	--	--	--	--

Visit our web site: www.flightlight.com



Flight Light Inc.
 2708 47th Ave.
 Sacramento, California, U.S.A.
 95822-3806

atg airports (formerly ALSTOM)
**ZA181 High Intensity
 Runway Centerline and
 Touch Down Zone Inset Light
 FAA Compliant: L-850A & B**

PH (916) 394-2800 FX (916) 394-2809
 TF (800) 806-3548 EM info@flightlight.com

Components

1	Body casting	
2/3	White (clear) prism	80-016069
2/3	Red dichroic prism	80-019141
2/3	Blank for prism aperture	80-040092
4	Prism gasket	80-033058
5	Prism clamp gasket	80-033069
6	Prism retaining clamp	80-032037
7	Lampholder	80-032040
8	Lamp retaining spring	80-032039
9	Lamp, MR16, 6.6A, 49W	80-008065
10	Lamp gasket	80-033077
11	Lamp by-pass disc assembly	80-031030
12	45W by-pass disc	80-021134
13	'O' ring seal	80-033070
14	Cable gland assembly	80-021114/5/6
15	'B' type plug lead	80-013001

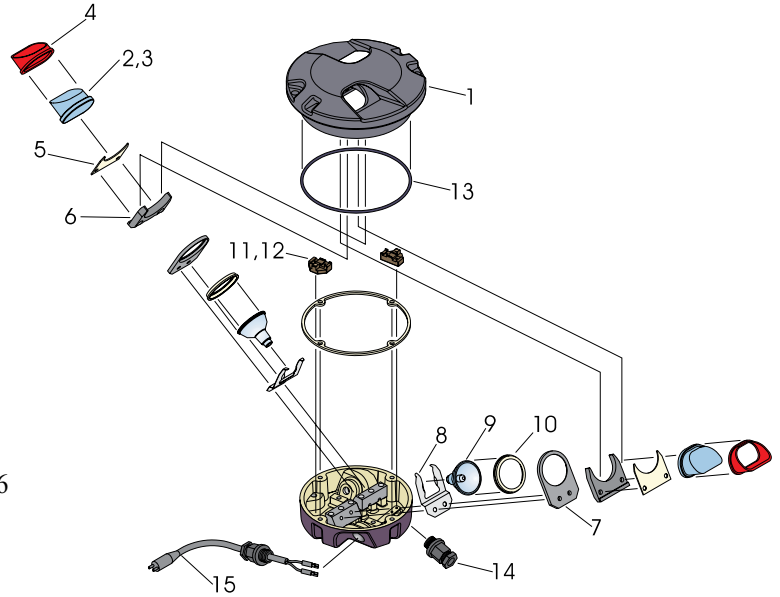

ZA181 on L-868 Base

1. ZA181 fixture
2. 12" FAA L-868B mounting adapter (30-AA122820)
3. FAA L-868 base (one piece)
4. Outer earth terminal
5. Inner earth terminal
6. Isolation transformer (L-830)
7. Secondary connection
8. Primary connector (L-823)
9. Grommet

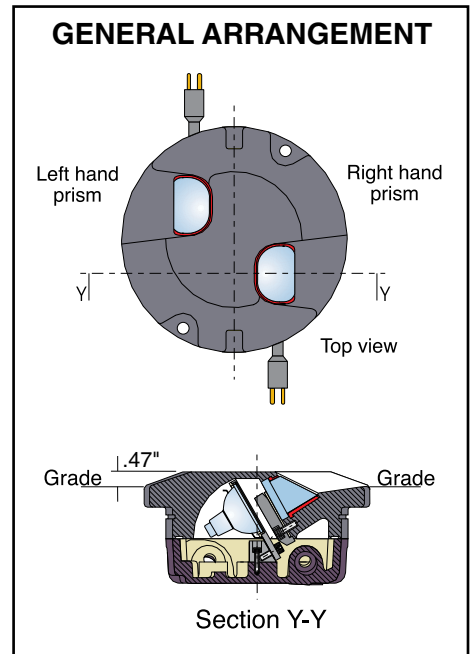
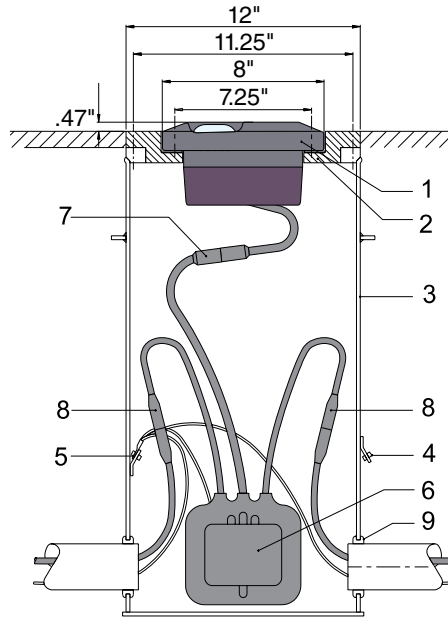

Visit our web site: www.flightlight.com



Flight Light Inc.
2708 47th Ave.
Sacramento, California, U.S.A.
95822-3806

atg airports (formerly ALSTOM)
ZA181 High Intensity
Runway Centerline and
Touch Down Zone Inset Light
FAA Compliant: L-850A & B

PH (916) 394-2800 FX (916) 394-2809
TF (800) 806-3548 EM info@flightlight.com

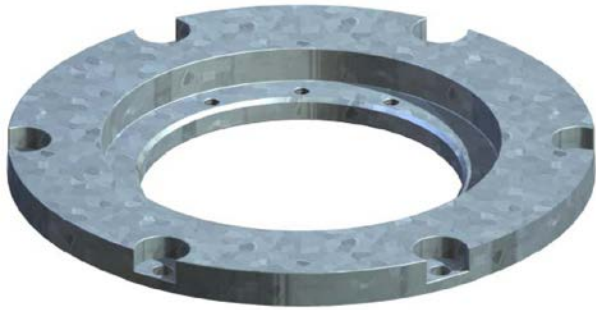

**L-868B 8"-12" Adapter/Flange Ring
(30-AA122820)**

1. Approved and Certified to FAA Advisory Circular AC150/5345-42F
Size: B=12"
 2. Adapter Plates are galvanized to ASTM-A123/
A123M-02
 3. (6) 7/16" Ø equally spaced, thru holes with 1-1/8"
Ø x 1/2" deep counter bore
 4. Standard Plate: (6) 3/8"-16 tapped holes
Metric Plate: (6) M10-1.5 tapped holes
 5. Standard Adapter Plates are shipped with:
 - (2) 3/8"-16 x 1-1/4" SS hex head bolts (10650202)
 - (2) 3/8", 2 piece locking washers (10680607)
 - (1) Bolt Set (6100) containing:
 - (6) 3/8"-16 x 1" SS hex head bolts (10650198)
 - (6) 3/8", 2 piece locking washers (10680607)
- Metric Adapter Plates are shipped with:
- (2) M10x1.5x30mm SS hex head bolts (10652820)
 - (2) 3/8", 2 piece locking washers (10680607)
 - (1) Bolt Set (6100M) containing:
 - (6) M10x1.5x30mm SS hex head bolts (10652820)
 - (6) 3/8", 2 piece locking washers (10680607)

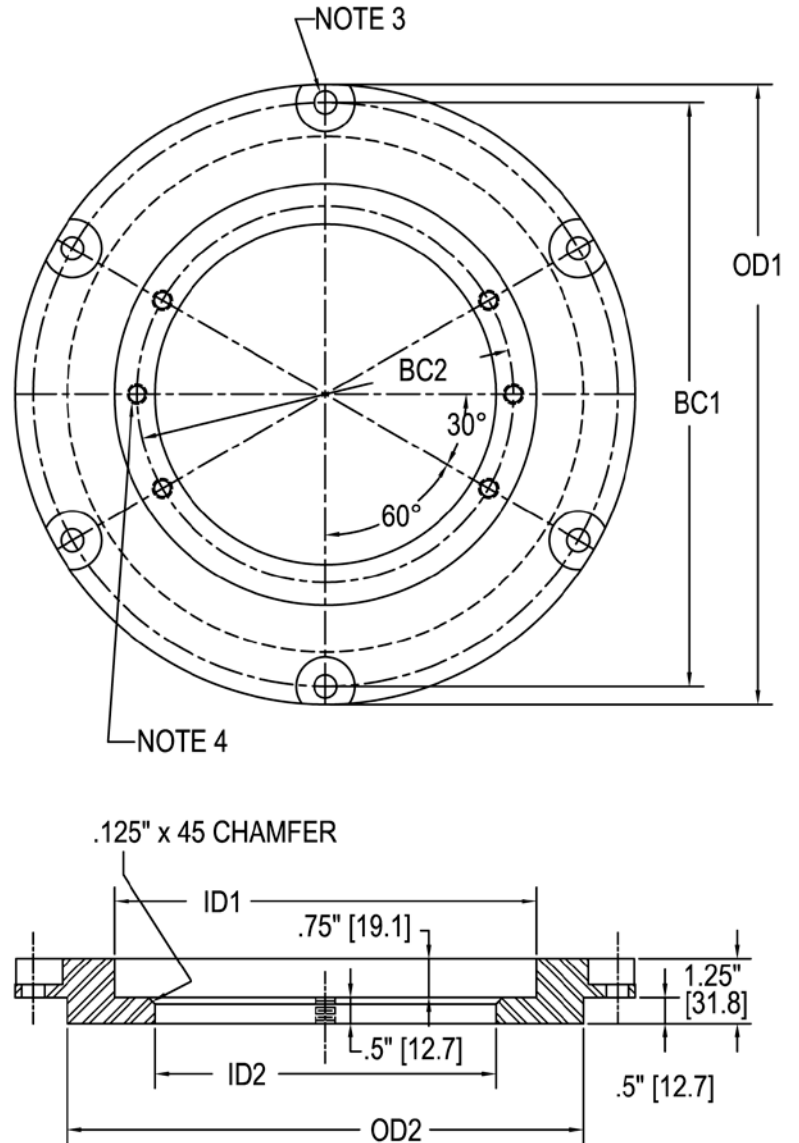

TYPE	OD1	BC1	OD2	ID1	BC2	ID2
30-AA122820	11.938" [303.2]	11.25" [285.8]	9.938" [252.4]	8.125" [206.4]	7.25" [184.2]	6.563" [166.7]

Add "M" to the end of the part number to note Metric Adapter Plate

[] = metric dimensions in mm

Visit our web site: www.flightlight.com